

Cuadro de protección SOLARBOX – DC-S

Protection enclosure SOLARBOX – DC-S

Dimensiones y características constructivas / Dimensions and constructional features

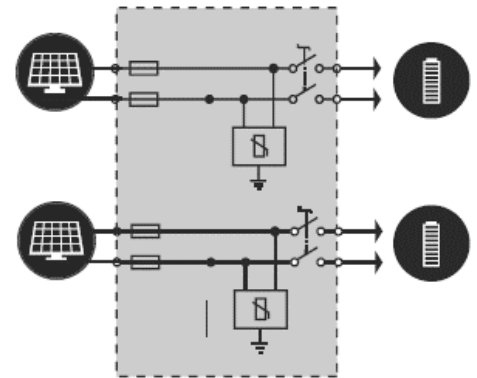
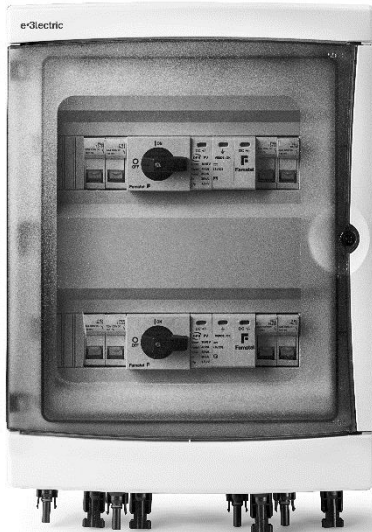

Código / Code

Referencia Reference	Entradas/Salidas Input/Output	Fusibles Fuses	Seccionador Switch	MC4
E3SBDC08 -FVC1SS	1 String / 1 MPPT	16 A	25 A	
E3SBDC12 -FVC2SS	2 String / 1 MPPT	16 A	32 A	
E3SBDC26 -FVC2SS	2 String / 2 MPPT	16 A	25 A	
E3SBDC26 -FVC4SS	4 String / 2 MPPT	16 A	32 A	
E3SBDC42 -FVC3SS	3 String / 3 MPPT	16 A	25 A	
E3SBDC42 -FVC6SS	6 String / 3 MPPT	16 A	32 A	
E3SBDC42 -FVC4SS	4 String / 4 MPPT	16 A	25 A	
E3SBDC54 -FVC8SS	8 String / 4 MPPT	16 A	32 A	
E3SBDC08 -FVS1SS	1 String / 1 MPPT	16 A	25 A	X
E3SBDC12 -FVS2SS	2 String / 1 MPPT	16 A	32 A	X
E3SBDC26 -FVS2SS	2 String / 2 MPPT	16 A	25 A	X
E3SBDC26 -FVS4SS	4 String / 2 MPPT	16 A	32 A	X
E3SBDC42 -FVS3SS	3 String / 3 MPPT	16 A	25 A	X

E3SBDC42 -FVS6SS	6 String / 3 MPPT	16 A	32 A	X
E3SBDC42 -FVS4SS	4 String / 4 MPPT	16 A	25 A	X

Características Técnicas / Technical Data

Tensión nominal / Rated voltage	1000 Vdc
Intensidad nominal / Rated current	25 A / 32 A
Temperatura de trabajo / Operating temperature	-25°C +40°C
Grado de Protección / Degree of Protection set	IP65
Resistencia al impacto / Impact resistance	IK08
Resistencia al hilo incandescente / Resistance glow wire	650°C
Dimensiones / Dimensions	E3SBDC08: 215 x 235 x 110 mm E3SBDC12: 215 x 310 x 110 mm E3SBDC26: 410 x 310 x 150 mm E3SBDC42: 405 x 260 x 120 mm E3SBDC54: 604 x 430 x 160 mm



Normativa /Regulations

Normativa aplicada /
Applied Standards

IEC 60364-7-712:2017, EN 61439-1:2012, EN 61439-2:2012, EN 60947-3:2009, EN 60269-6:2011, EN 61643-11:2013, EN 50539-11:2013

Información logística y embalaje / Logistics and packaging Information

Cantidad mínima de pedido: 1 unidad / Minimun quantity order: 1 unit

Código arancelario / Tariff code: HS 85381000

Referencia /Refreence	Embalaje / Packaging	Cantidad/Quantity	Peso neto – Peso bruto / Net weight –Grossweight	Dimensiones (mm)/ Dimensions (mm)
E3SBDC08	Caja	1 u.	1954 gr	250 x 250 x 120
E3SBDC12	Caja	1 u.	2378 gr	330 x 250 x 125
E3SBDC26	Caja	1 u.	3809 gr	330 x 450 x 160
E3SBDC42	Caja	1 u.	5251 gr	350 x 600 x 160
E3SBDC54	Caja	1 u.	7411 gr	640 x 430 x 160

Instrucciones / Instructions

Uso /Use	<ul style="list-style-type: none"> Las operaciones de instalación, puesta en servicio, inspección y mantenimiento sólo podrán ser realizadas por personal adecuadamente cualificado y formado en temas eléctricos y de seguridad aplicables. El cumplimiento de las instrucciones de seguridad no excusa el cumplimiento de otras normas específicas de la instalación, el lugar, el país u otras circunstancias que afecten al cuadro (R.D.614/2001, REBT, etc...). <p><i>Installation, commissioning, inspection and maintenance operations can only be carried out by suitably qualified personnel trained in applicable electrical and safety issues. Compliance with the safety instructions does not excuse compliance with other regulations specific to the installation, the place, the country or other circumstances that affect the table (R.D .614 / 2001, REBT, etc ...).</i></p> <ul style="list-style-type: none"> No se debe instalar el equipo sobre una superficie de material inflamable, ni en ambientes que pudieran estar bajo influencia de productos agresivamente corrosivos. <p><i>Do not install the equipment on a surface of flammable material, or in environments that may be under the influence of aggressively corrosive products.</i></p>
Mantenimiento / Maintenance	<ul style="list-style-type: none"> Realizar inspecciones visuales periódicas de la envolvente. Se deben buscar grietas, golpes, etc., que puedan afectar al funcionamiento normal del cuadro y al grado IP designado. <p><i>Perform periodic visual inspections of the enclosure. Look for crack, bumps, etc., that may affect the normal operation of the enclosure and the designated IP degree.</i></p>