

**DOBLE INTERRUPTOR ESTANCO/ WATERPROOF DOUBLE SWITCH**

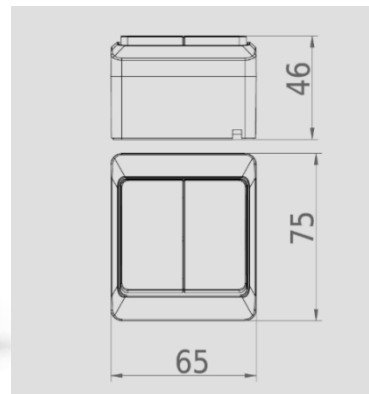

DIRECTIVA APLICADA / DIRECTIVE APPLIED	2014/35/UE REBT 2002: Reglamento de Baja Tensión REBT 2002: Spanish Low Voltage Electrotechnical Regulation
GRADO DE PROTECCIÓN DEGREE OF PROTECTION	IP54
DIMENSIONES EXTERNAL/ EXTERNAL DIMENSIONS	65mm x 75mm x 46mm
COLOR COLOUR	Blanco RAL 9003/ Negro White RAL 9003 / Black
RESISTENCIA HILO INCANDESCENTE RESISTANCE WIRE GLOW	Partes activas / Active parts: 850 °C Otras partes / Other parts: 650 °C
RESISTENCIA A LA TEMPERATURA POR PRE- SIÓN DE BOLA. TEMPERATURE RESISTANCE BALL PRESSURE	Partes activas / Active parts: 125 °C
ESTABILIDAD DIMENSIONAL DIMENSIONAL STABILITY	- 25 °C + 85 °C
CARACTERÍSTICAS ELÉCTRICAS ELECTRICAL CHARACTERISTICS	Intensidad /Current: 10 AX Tensión / Voltage: 250 V ~ Frecuencia / Frequency: 50 / 60 Hz
OTRAS CARACTERISTICAS OTHER CHARACTERISTICS	Borne con tornillo / Screw type terminal Método de montaje: Superficie, Instalación fija Mounting method: Surface Type, Fixed Installation. Lugar previsto: Exterior Intended environment: Outdoor
NORMAS APLICADAS / APPLIED STANDARD	EN 60669-1