

Base de empotrar inclinada 10° con microinterruptor / Microswitch angled panel socket 10°

Referencias y Dimensiones / References and Dimensions

3P=2P+T
4P=3P+T
5P=3P+T+N

230V 50/60Hz	400V 50/60Hz
-----------------	-----------------



Amp	Poles	Pack unit	Poles: 3P 4P 5P Hour P: 6h 9h 9h	Poles: 3P 4P 5P Hour P: 9h 6h 6h
16	3	10	23M230	
	4	10		23M330
	5	5		23M331
32	3	4	23M233	
	4	4		23M332
	5	3		23M333

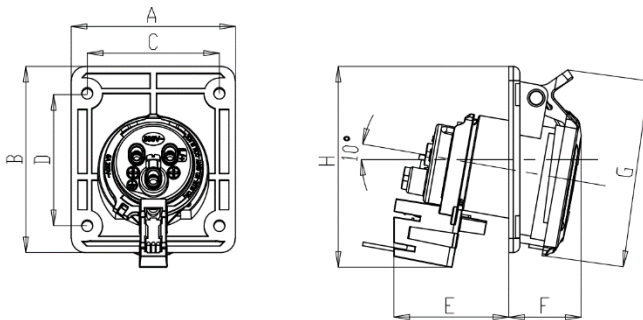

Poles	16A			32A		
	3	4	5	3	4	5
A	75	75	75	80	80	80
B	85	85	85	95	95	95
C	60	60	60	70	70	70
D	60	60	60	60	60	60
E	52	61	61	67	67	67
F	26	34	37	40	40	40
G	86	94	102	108	108	108
H	90	102	111	114	114	120
Connection type	Conexión por tornillo / Screw terminals					
Wire flexible (mm ²)	1-2.5			2.5-6		
Weight (g)	123	139	157	220	239	262

Dimensiones en mm / Dimensions in mm

Características Técnicas / Technical Data

Tensión nominal / Rated voltage	■ 200...250V ■ 380...415V
Intensidad Nominal / Rated current	16A -32A
Frecuencia / Frequency	50 / 60 Hz
Resistencia de aislamiento / Insulating resistance	>10MΩ
Rigidez dieléctrica / Dielectric strenght	2,5 kV 60s
Material / Material	PA6/ABS
Contactos / Contacts	Latón / Brass
Microinterruptor / Micro switch	Contacto NO-NC / Contact NO-NC Longitud cable / Cable length : 50cm
Temperatura de trabajo / Working temperature	-25°C / 40°C
Resistencia al impacto / Impact resistance	IK08
Grado de protección / Protection degree	IP54
Ensayo hilo incandescente / Glow wire test	850°C partes soportan partes activas / parts support live parts 650°C Otras partes / Other parts



Normativa / Regulations

Normativa aplicada / Applied Standards

IEC 60309-1; IEC 60309-2; EN 61058-1-1:2016, EN IEC 61058-1:2018

Información logística y embalaje / Logistics and packaging Information

Cantidad mínima de pedido: 1 unidad / Minimum quantity order: 1 unit

Código arancelario / Tariff code: HS 85366990

Embalaje <i>Packaging</i>	Cantidad <i>Quantity</i>	Peso neto – Peso bruto <i>Net weight – Gross weight</i>	Código EAN <i>EAN code</i>
Caja Individual / Single box	1	0,122 kg	8429760829720
Estuche / <i>Inner Box</i>	10	1,22 kg	18429760829727
Caja Exterior / <i>Master Box</i>	120	14,64 kg	28429760829724

Instrucciones / Instructions

Uso / <i>Use</i>	<ul style="list-style-type: none"> Las operaciones de instalación, puesta en servicio, inspección y mantenimiento sólo podrán ser realizadas por personal adecuadamente cualificado y formado en temas eléctricos y de seguridades aplicables. El cumplimiento de las instrucciones de seguridad no excusa el cumplimiento de otras normas específicas de la instalación, el lugar, el país u otras circunstancias que afecten al cuadro (R.D.614/2001, REBT, etc...). Installation, commissioning, inspection and maintenance operations can only be carried out by suitably qualified personnel trained in applicable electrical and safety issues. Compliance with the safety instructions does not excuse compliance with other regulations specific to the installation, the place, the country or other circumstances that affect the table (R.D.614 / 2001, REBT, etc...). No se debe instalar el equipo sobre una superficie de material inflamable, ni en ambientes que pudieran estar bajo influencia de productos agresivamente corrosivos. <i>Do not install the equipment on a surface of flammable material, or in environments that may be under the influence of aggressively corrosive products.</i>
Mantenimiento / <i>Maintenance</i>	<ul style="list-style-type: none"> Realizar inspecciones visuales periódicas de la envolvente. Se deben buscar grietas, golpes, etc., que puedan afectar al funcionamiento normal del cuadro y al grado IP designado. <i>Perform periodic visual inspections of the enclosure. Look for crack, bumps, etc., that may affect the normal operation of the enclosure and the designated IP degree.</i>